

Electrical Diagram

40A 41A 42A



235 AVE LABROSSE, POINTE-CLAIRE,
MONTREAL, (QUEBEC) CANADA, H9R 1A3
TEL.: (514) 695-0772 - 800-667-0772
FAX: (514) 695-0248 - 800-667-0248
www.doorlec.com

For more information please visit www.devancocanada.com or call toll free at 1-855-931-3334

ELECTRICAL DIAGRAM 40 A

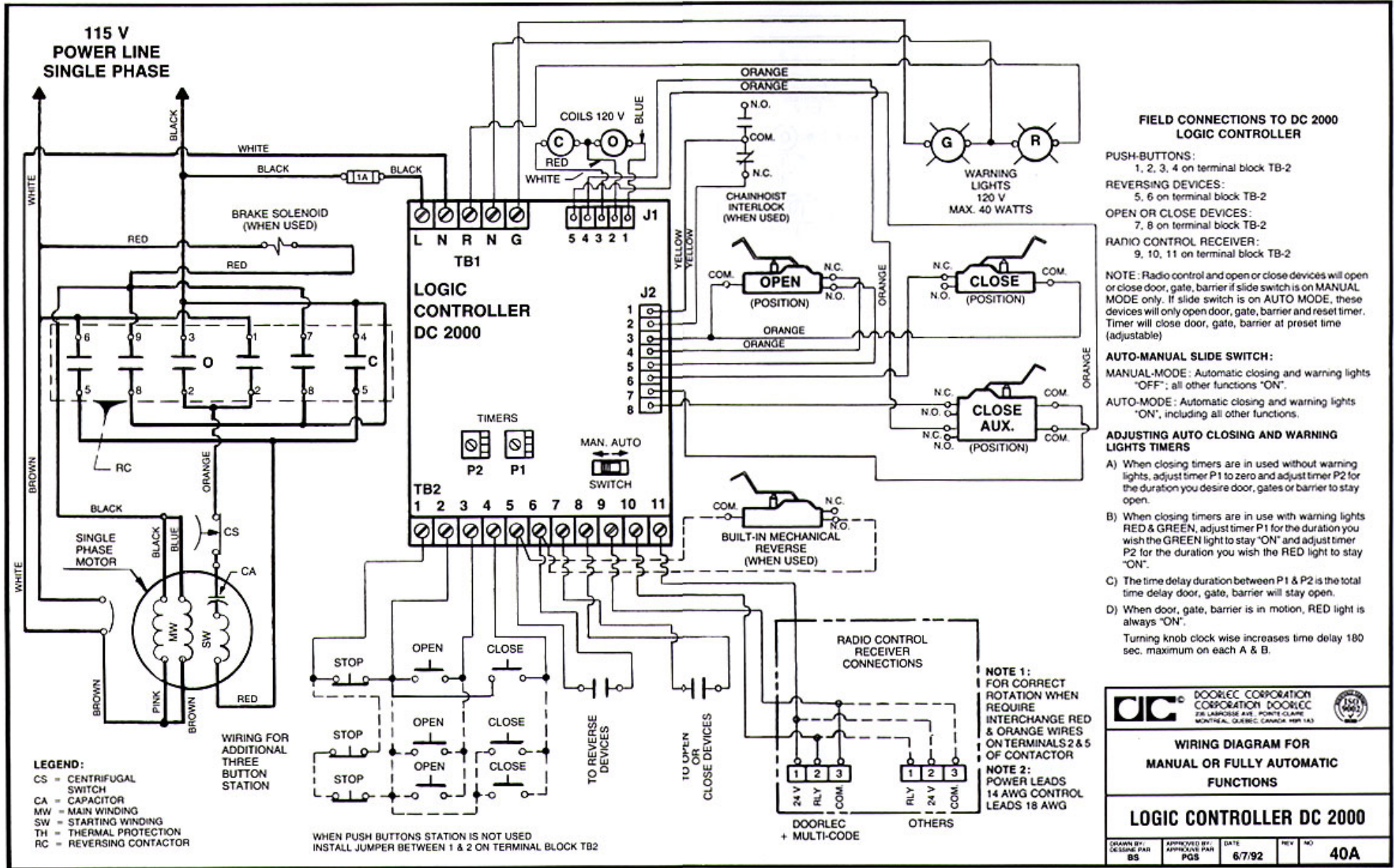

ELECTRICAL DIAGRAM 41 A

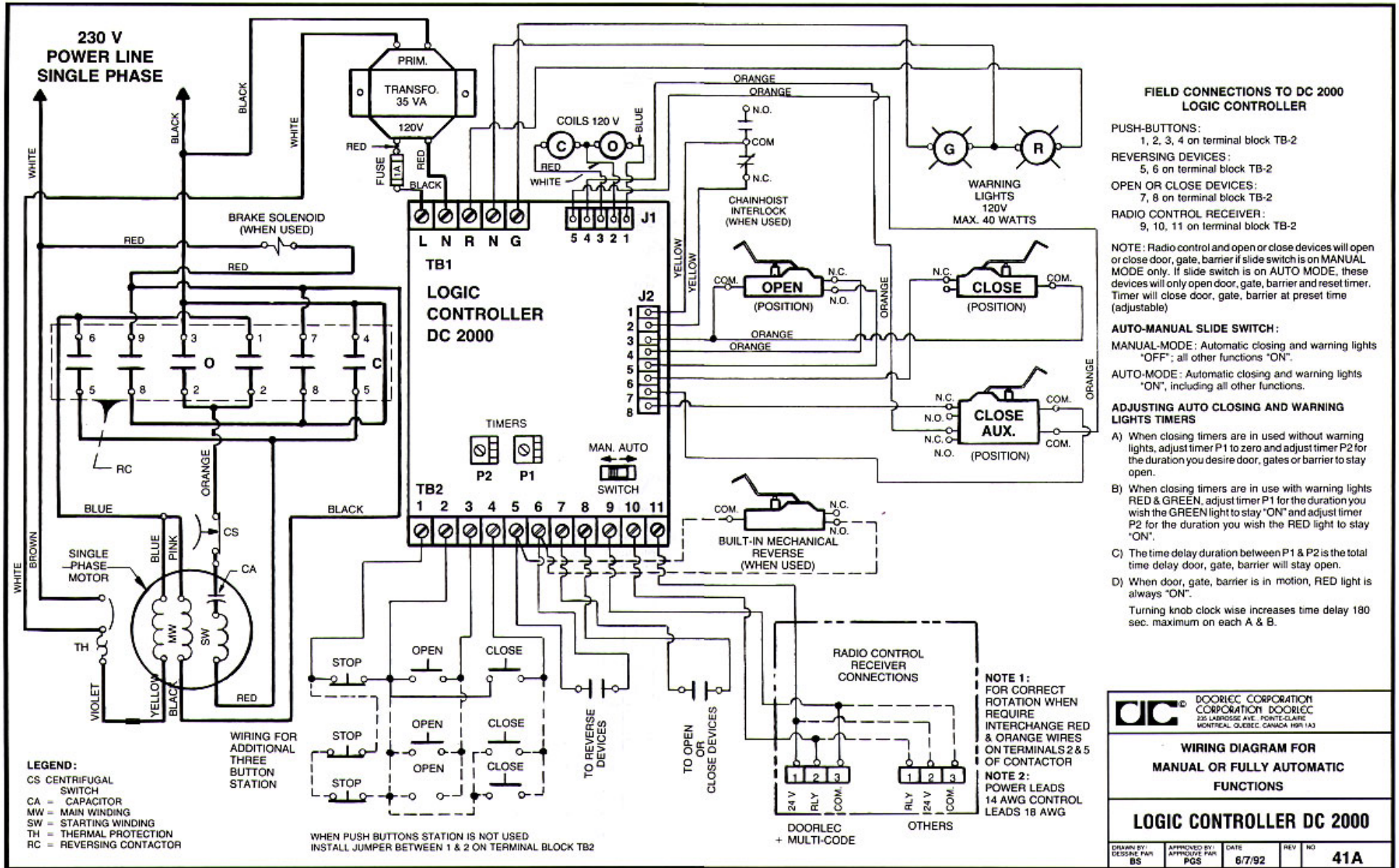

DC DOORLEC CORPORATION
CORPORATION DOORLEC
235 LAPOINTE AVE. POINTE-CLAIRE
MONTREAL, QUEBEC CANADA H9R 1A3

**WIRING DIAGRAM FOR
MANUAL OR FULLY AUTOMATIC
FUNCTIONS**

LOGIC CONTROLLER DC 2000

DRAWN BY: DESIRÉE PAIN BS	APPROVED BY: PAGES PGS	DATE 6/7/92	REV NO 41A
---------------------------------	------------------------------	----------------	---------------

ELECTRICAL DIAGRAM 42 A

